

Watch Fit Guide for Women & Men

We created this printable size guide for your convenience. To determine the scale that looks best on you, print this PDF at 100% for accurate sizing. Then, cut at your preferred size option and hold it against your wrist.

2 INCHES

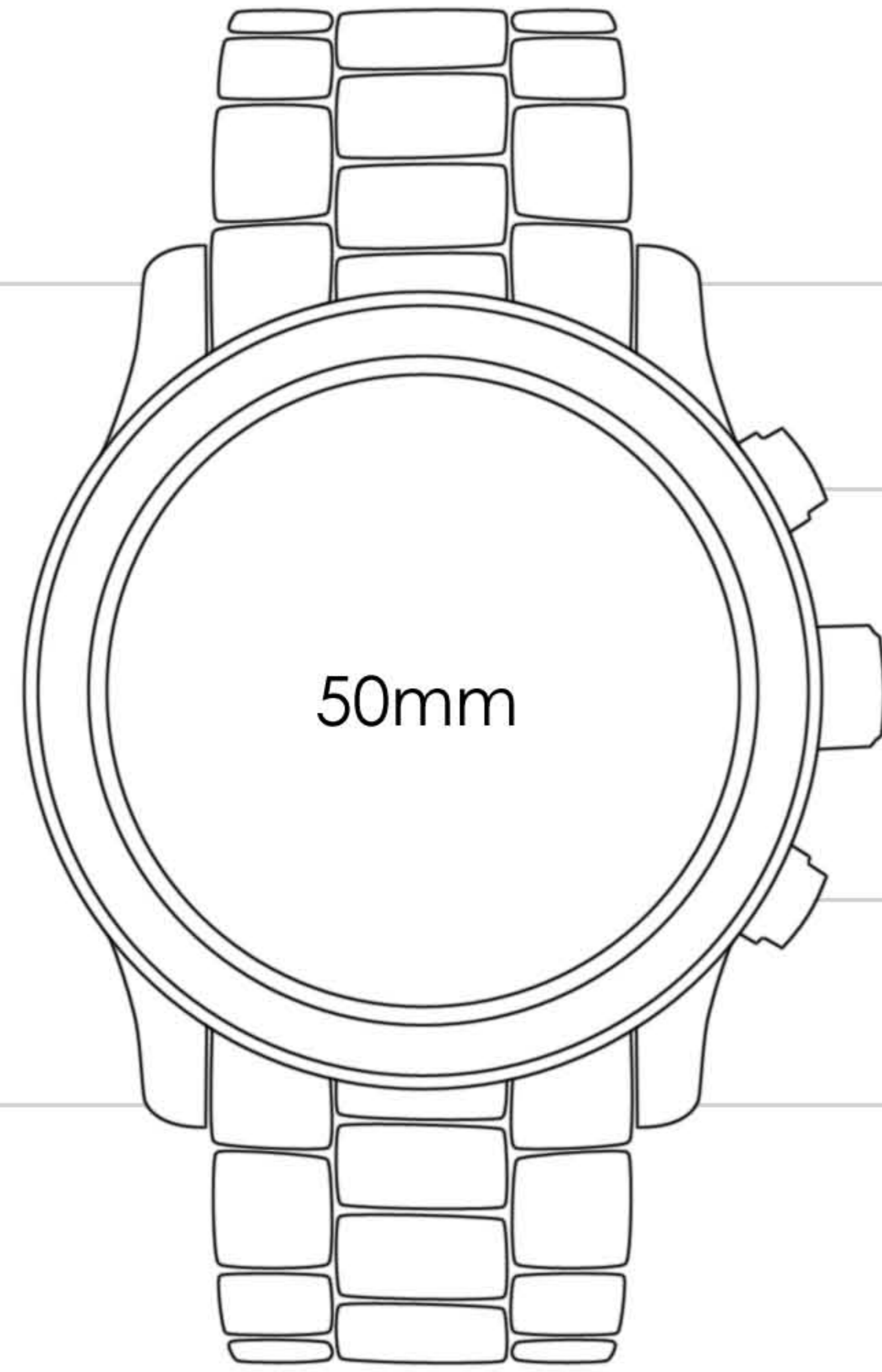

45mm

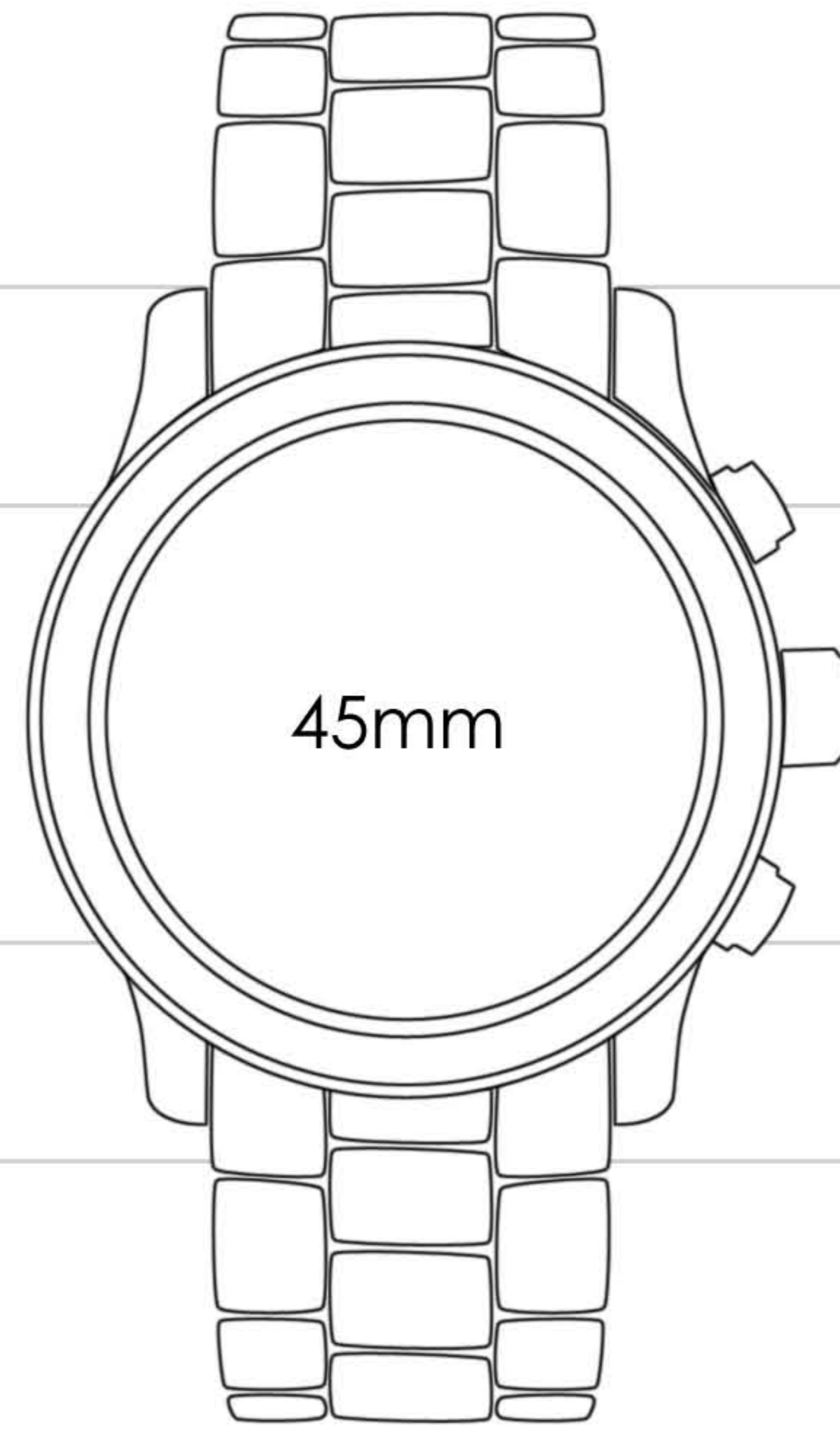

40mm

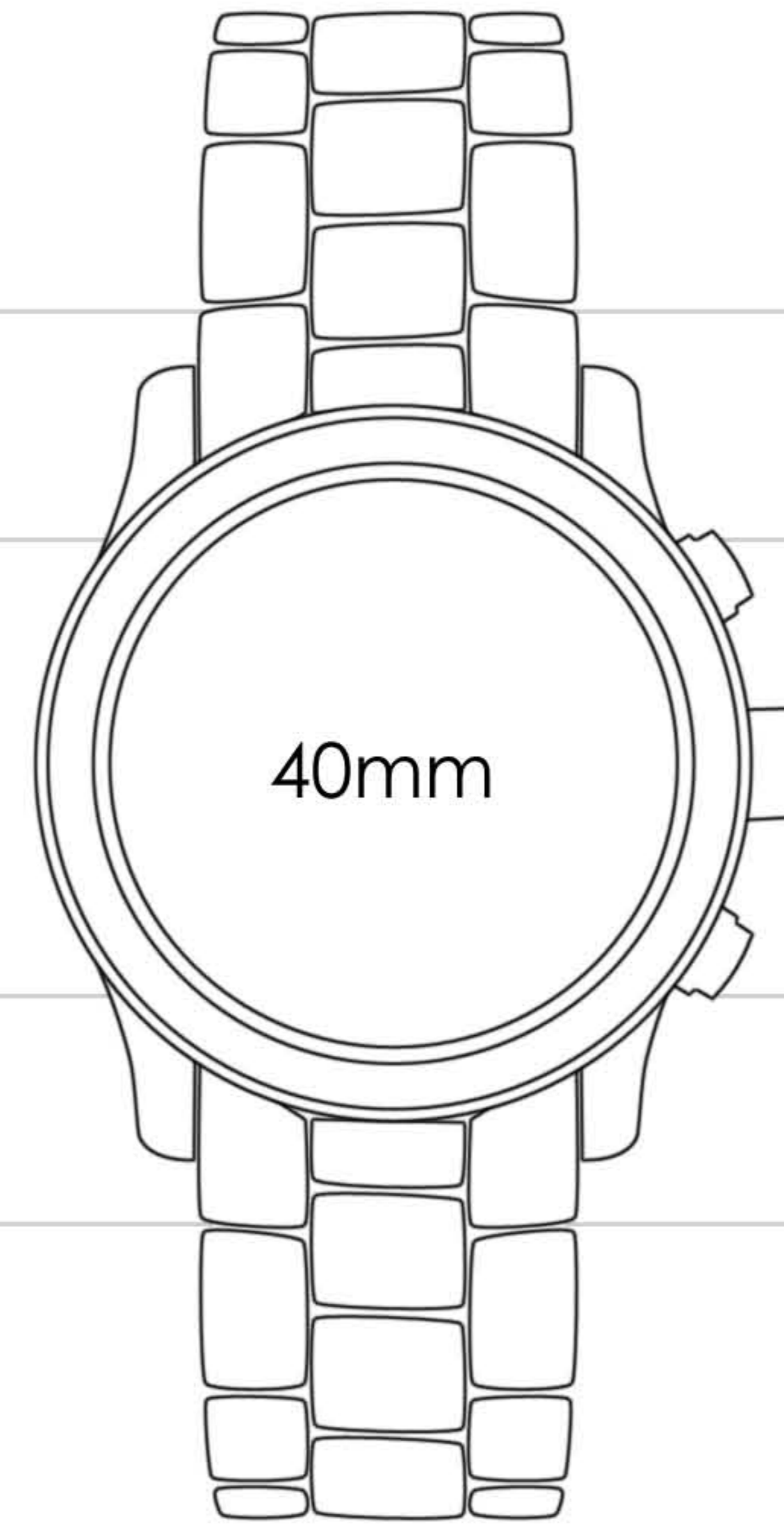

38mm

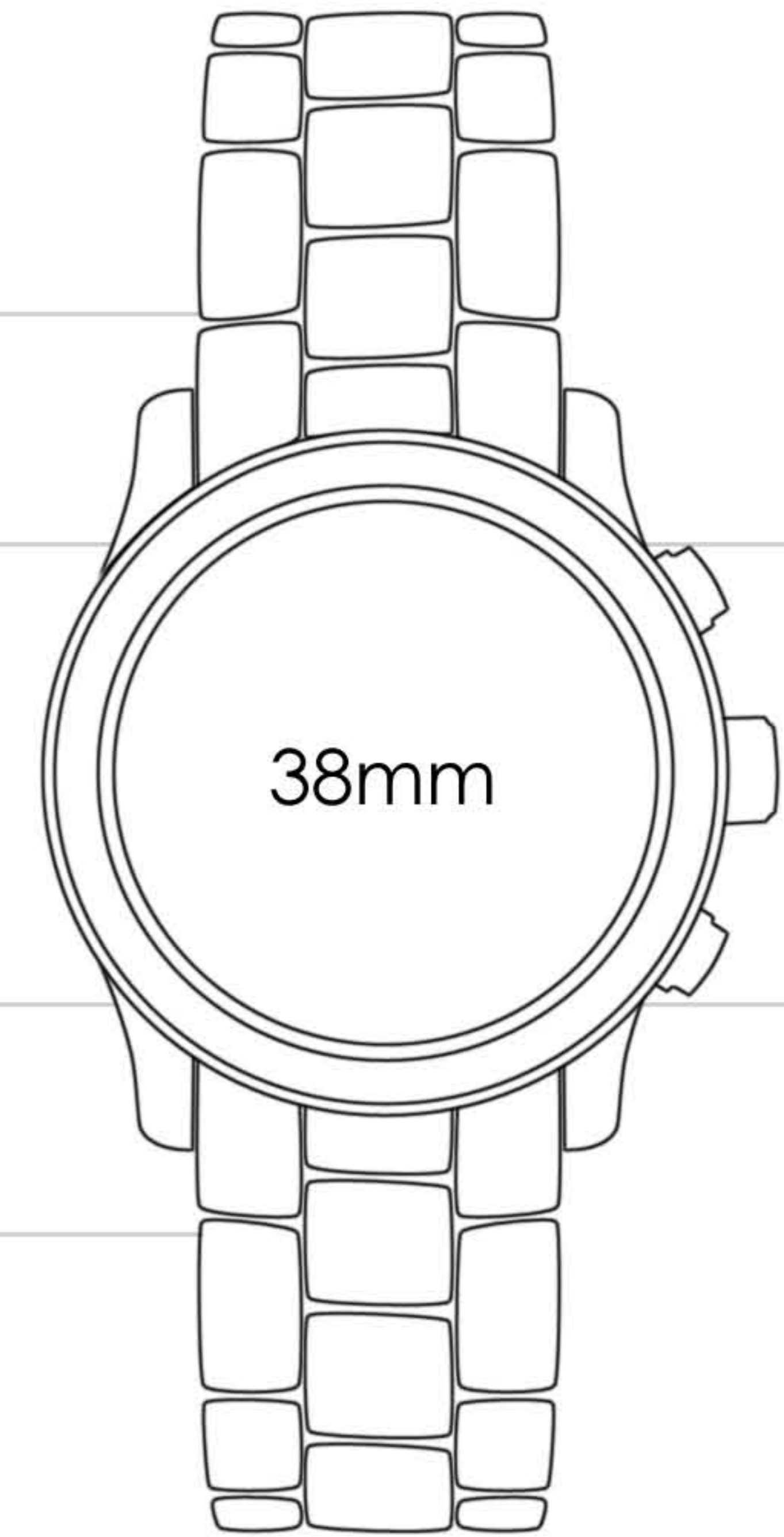

1 INCH

2 INCHES

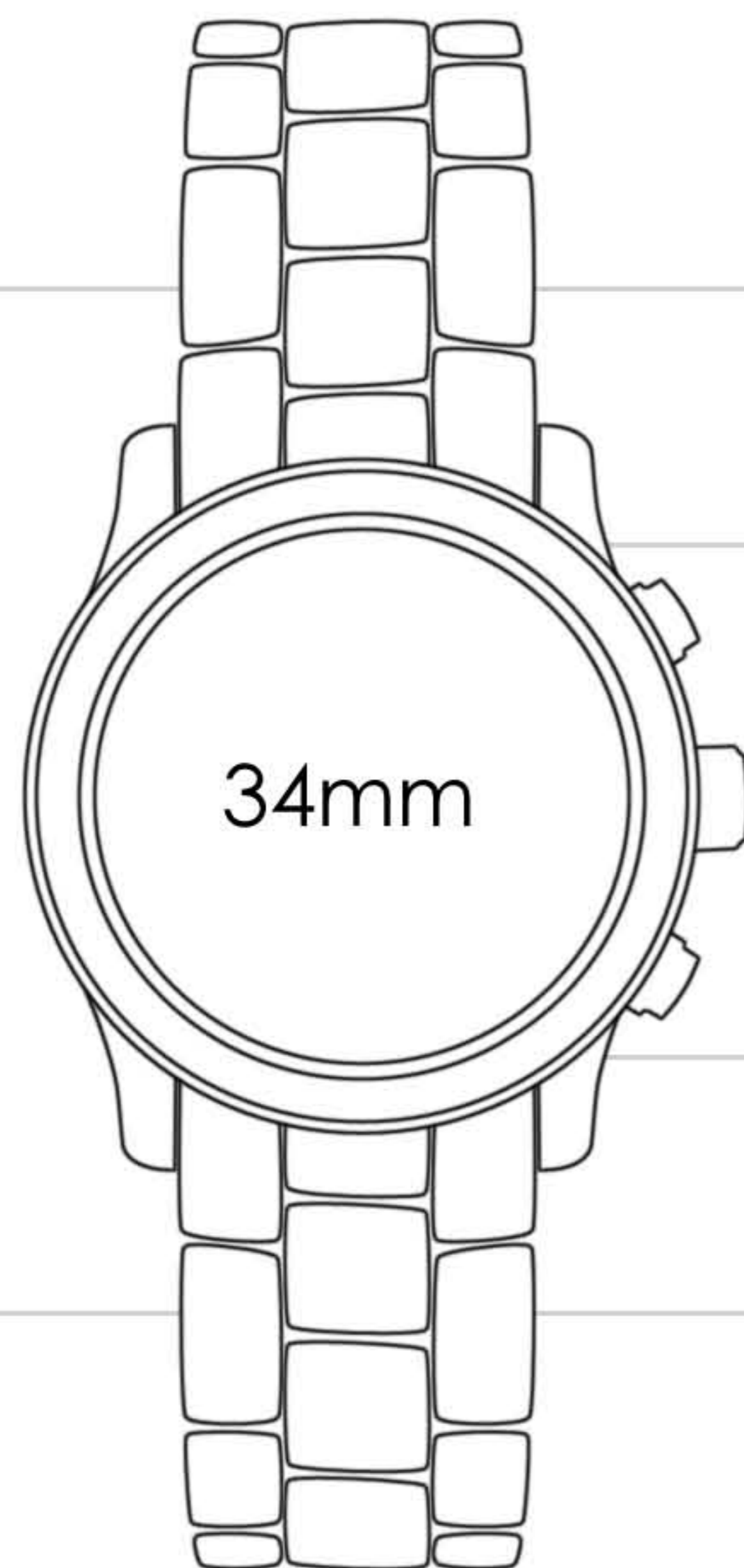

30mm

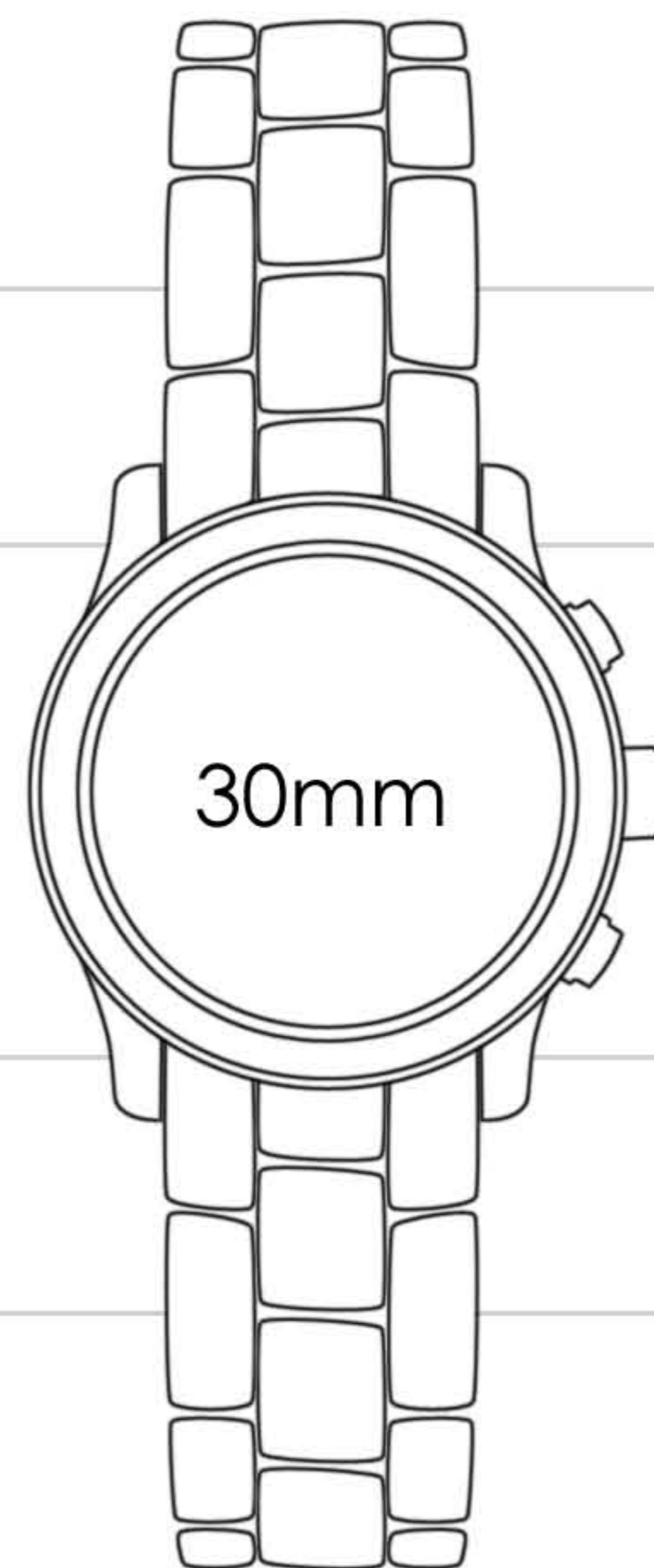

24mm



20mm

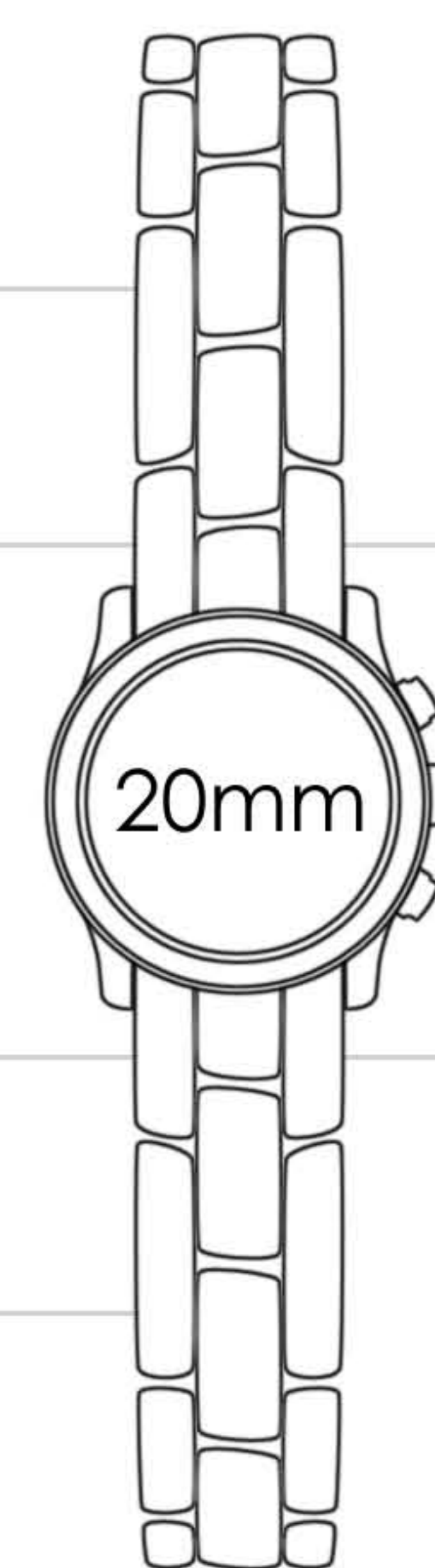

1 INCH